

DESIGN 64



PBI

PACKAGED BACKWARD INCLINED FANS



DESIGN 64 PBI

PACKAGED BACKWARD INCLINED FANS

Developed initially for the dust collector industry, Chicago's new Packaged Backward Inclined (PBI) fan is also ideal for an expanding range of applications, such as laser cutters, air filtration, and pneumatic conveying, up to 150°F. Chicago's PBI fan is also the perfect replacement for older, less reliable fans. The rugged PBI fan provides the performance you need and the reliability you want, backed by **Chicago's 3-year warranty**.

Chicago's PBI fan is the right choice for your requirements, designed to increase the stable operating range by over 20%. This enables you to offer a wider performance range and thereby eliminate fan sizes. Chicago's Design 64 PBI fan is offered in 12 sizes from 122 to 365 and in standard widths of 100%, 75% and 50%. With the availability of three motor RPMs, a PBI fan will meet all your necessary performance and physical specifications.

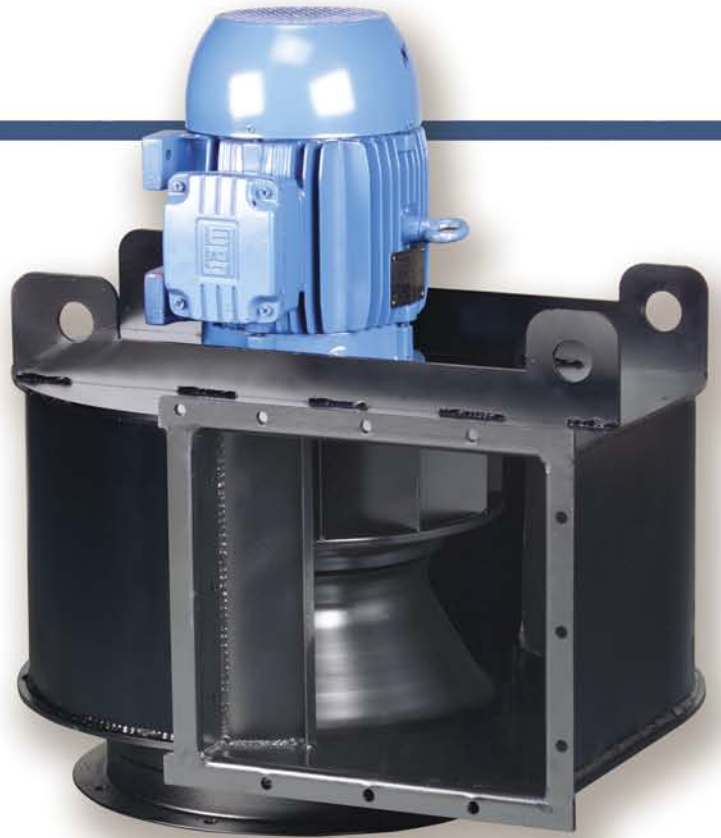

Since Chicago's PBI is a direct drive fan, initial cost is less and belt drive problems are eliminated – periodic belt adjustments, belt squeal, horsepower guesswork. It all adds up to a more energy efficient, more dependable fan. In fact, Chicago's run tested PBI fan's most important benefit is the reliability we add to your product.

Chicago Blower representatives located throughout North America and around the globe welcome the opportunity to discuss and evaluate your application. Put Chicago Blower's experience and "Industrial Quality" fan building expertise to work for you.

Chicago Blower Corporation
is certified for ISO 9001.



This typical dust collector installation for a laser cutter recirculates the clean exhaust within the facility. The optional outlet damper, outlet transition and outlet silencer complete the installation.

The Performance you need... the Reliability you want

New High Performance Wheel

Chicago has developed a new wheel for the PBI fan. The wheel uses flat backward inclined steel blades for maximum performance in hostile environments. The PBI wheel, coupled with the streamlined inlet, virtually eliminates vibration and reduces noise levels dramatically.

For applications processing only fumes or very light dust, Chicago's airfoil wheel is available. The airfoil configuration results in greater energy efficiency and lower sound levels. See fan.net for airfoil performance and sound data.

Rugged Housing

Heavy gauge steel and added drive side support gussets contribute to extended vibration-free operation, critical for any installation. Continuous welding of the housing sides to the scroll assures air tight seams. The fan's support gussets have four built-in lifting eyes.

Punched Flanged Outlet/Inlet

Equipped as standard, both the inlet and outlet are flanged and punched for easier installation. The outlet has welded corners to allow for bolting of ductwork, dampers, silencers or screens directly to the fan. An optional universal inlet flange that bolts to the equipment has a larger opening and larger diameter bolt circle.

C-Face Motor Mount

Allows C-face motors to mount directly to the fan housing, creating an airtight fit-up with no shaft seal. As the motor weight is also centered over the wheel, stability is improved when running in the vertical position.

Withstands Adverse Environments

Since some dust collector fans are installed outside the facility and subject to year-round environments, the C-face motor bolts directly to the drive side housing. The motor is then caulked with adhesive sealant to provide weather-proofing.



Refer to Chicago Blower's fan.net for performance, fan curves and sound data.

For software and assistance, contact your local Chicago Blower sales engineer.

Available Options

Square Housing

The PBI fan is also available in the square housing pioneered by Chicago Blower. Housings have continuously welded air-tight seams with all edges flanged for exceptional rigidity, thereby allowing the fan to be installed in any of four discharge positions.



Square Housing with AMCA Type C Construction.

Outlet Damper

Outlet dampers are often selected for their low initial cost and simple operation. Dampers have punched flanges on both ends to simplify fan and duct connections. Parallel acting blades are standard with opposed blades available.

Alternate Widths

To reach more precise performance or physical requirements, alternate widths of 75% and 50% are readily available. For other widths consult the factory.

Inlet/Outlet Screens

Welded steel screen mounts entirely within the inlet cone. Outlet screens are of expanded metal design.

Access Door

A flush mounted rectangular access door is available for quick inspection and clean-out of material build-up. The door features quick opening tension clamps with neoprene gasket.

Drain

PBI fans can be furnished with a half coupling drain and plug to facilitate convenient and easy power washing.

Spark Resistant Construction

For spark resistant construction, AMCA Type C consists of aluminum inlet cone and buffer between wheel backplate and housing. AMCA Type B construction is also available.

Fan Selection

Page 5 contains multi-rating tables for Design 64 PBI fans. Each section provides data for a particular motor speed. Under each pressure (SP) rating, the Volume (CFM) and horsepower (BHP) is listed for each fan size. For pressures not provided in the tables, simply interpolate between two given pressures.

Example: 5000 CFM, 120°F, 2500' elevation, 5" SP

1. From the Correction Table, the correction factor for 120° and 2500' elevation is 1.20.
2. The equivalent SP at 70°F and sea level equals 5" SP X 1.20 = 6" SP.
3. Enter the table at 6" SP. You would select a Size 165 PBI at 3500 RPM for 5086 CFM, requiring 7.86 BHP
4. To correct the BHP to 120°F and 2500' elevation, divide by the same correction factor. 7.86/1.20 = 6.55 BHP.

TEMPERATURE AND ALTITUDE CORRECTION

AIR TEMP (F°)	ALTITUDE (feet) with BAROMETRIC PRESSURE (HG)									
	0' 29.92	500' 29.38	1000' 28.86	1500' 28.33	2000' 27.82	2500' 27.31	3000' 26.82	3500' 26.32	4000' 25.84	5000' 24.90
-15	.79	.81	.82	.84	.85	.87	.88	.90	.96	1.00
0	.87	.88	.90	.92	.93	.95	.97	.99	1.00	1.04
70	1.00	1.02	1.04	1.06	1.08	1.10	1.12	1.14	1.16	1.20
100	1.06	1.08	1.10	1.12	1.14	1.16	1.18	1.20	1.22	1.27
150	1.15	1.17	1.19	1.22	1.24	1.26	1.28	1.31	1.33	1.38
200	1.25	1.27	1.29	1.32	1.34	1.36	1.39	1.42	1.44	1.50
250	1.34	1.36	1.39	1.41	1.44	1.47	1.49	1.52	1.55	1.61
300	1.43	1.46	1.49	1.51	1.54	1.57	1.60	1.63	1.66	1.72
350	1.53	1.56	1.58	1.61	1.64	1.67	1.70	1.74	1.77	1.84
400	1.62	1.65	1.68	1.71	1.75	1.78	1.81	1.84	1.88	1.95
500	1.81	1.84	1.88	1.91	1.95	1.98	2.02	2.06	2.10	2.18
600	2.00	2.04	2.07	2.11	2.15	2.19	2.23	2.27	2.32	2.40
650	2.09	2.13	2.17	2.21	2.25	2.29	2.34	2.38	2.43	2.52
700	2.19	2.23	2.27	2.31	2.35	2.40	2.44	2.49	2.53	2.63
800	2.38	2.42	2.48	2.51	2.56	2.60	2.65	2.70	2.75	2.86

Correction factors for temperature (F) and altitude (above sea level): standard air = .075 lbs. per cubic foot at sea level, 29.92" barometric pressure and 70° F



Chicago Blower Corporation certifies that the Design 64 PBI Fans shown or herein are licensed to bear the AMCA Seal. The ratings shown are based on tests and procedures performed in accordance with AMCA Publication 211 and comply with the requirements of the AMCA Certified Ratings Program.

Design 64 PBI Performance Ratings

3500 RPM

FAN SIZE	0"SP		1"SP		2"SP		3"SP		4"SP		5"SP		6"SP	
	CFM	BHP	CFM	BHP	CFM	BHP	CFM	BHP	CFM	BHP	CFM	BHP	CFM	BHP
122	3555	2.38	3359	2.56	3177	2.68	2988	2.78	2770	2.86	2500	2.89	2154	2.85
135	4758	3.87	4540	4.13	4337	4.30	4136	4.44	3919	4.56	3670	4.65	3370	4.70
150	6527	6.55	6282	6.92	6053	7.18	5832	7.39	5605	7.57	5361	7.73	5086	7.86
165	8687	10.56	8416	11.07	8160	11.43	7915	11.73	7615	12.06	7419	12.24	7149	12.44
182	12061	20.46	11689	20.92	11337	21.30	11000	21.63	10672	21.90	10347	22.14	10021	22.33
200	15858	32.15	15465	32.95	15074	33.48	14698	33.94	14334	34.34	13975	34.69	13620	34.99
222	21834	54.79	21400	55.97	20960	56.72	20535	57.40	20121	58.00	19716	58.54	19318	59.02
FAN SIZE	7"SP		8"SP		9"SP		10"SP		11"SP		12"SP		13"SP	
	CFM	BHP	CFM	BHP	CFM	BHP	CFM	BHP	CFM	BHP	CFM	BHP	CFM	BHP
122	1709	2.64												
135	3003	4.67	2552	4.48										
150	4768	7.94	4394	7.95	3953	7.84	3431	7.53						
165	6852	12.62	6518	12.75	6138	12.82	5703	12.73	5203	12.79	4629	12.18		
182	9688	22.49	9343	22.61	8980	22.68	8595	22.71	8181	22.68	7734	22.58	7249	22.38
200	13263	35.25	12900	35.47	12528	35.65	12143	35.78	11740	35.87	11315	35.90	10865	35.87
222	18922	59.45	18526	59.84	18127	60.17	17723	60.47	17309	60.71	16884	60.91	16444	61.06
FAN SIZE	14"SP		15"SP		16"SP		17"SP		18"SP		19"SP		20"SP	
	CFM	BHP	CFM	BHP	CFM	BHP	CFM	BHP	CFM	BHP	CFM	BHP	CFM	BHP
182	6719	22.06	6139	21.59										
200	10385	35.76	9872	35.55	9320	35.23	8727	34.77						
222	15987	61.15	15508	61.15	15007	61.13	14479	61.00	13921	60.77	13332	60.42	12707	59.93
FAN SIZE	21"SP		22"SP		23"SP									
	CFM	BHP	CFM	BHP	CFM	BHP								
222	12043	59.28	11339	58.45	10590	57.39								

1760 RPM

FAN SIZE	0"SP		1"SP		2"SP		3"SP		4"SP		5"SP		6"SP	
	CFM	BHP	CFM	BHP	CFM	BHP	CFM	BHP	CFM	BHP	CFM	BHP	CFM	BHP
122	1788	0.30	1399	0.36										
135	2393	0.49	1976	0.58	1306	0.57								
150	3282	0.83	2824	0.96	2228	1.01								
165	4368	1.35	3863	1.52	3294	1.62	2369	1.56						
182	6065	2.60	5374	2.78	4714	2.87	3921	2.87						
200	7974	4.09	7216	4.36	6504	4.51	5720	4.56	4739	4.49				
222	10980	6.97	10127	7.37	9334	7.60	8520	7.74	7593	7.78	6463	7.64		
245	14082	9.44	13348	10.34	12747	10.92	12162	11.38	11457	11.80	10499	12.15	9151	12.20
270	18847	15.34	18024	16.61	17333	17.45	16701	18.11	16025	18.70	15026	19.26	14141	19.73
300	26679	29.02	25755	30.95	24945	32.30	24204	33.32	23459	34.14	22642	34.83	21682	35.37
330	35510	46.73	34483	49.38	33561	51.34	32724	52.86	31917	54.09	31088	55.14	30185	56.05
365	46102	72.21	44974	75.72	43939	78.45	42996	80.61	42105	82.40	41224	83.92	40314	85.26
FAN SIZE	7"SP		8"SP		9"SP		10"SP		11"SP		12"SP		13"SP	
	CFM	BHP	CFM	BHP	CFM	BHP	CFM	BHP	CFM	BHP	CFM	BHP	CFM	BHP
270	12730	19.89	10873	19.32										
300	20509	35.69	19053	35.63	17243	35.00	15010	33.67						
330	29154	56.80	27944	57.33	26500	57.52	24772	57.21	22705	56.23				
365	39334	86.44	38242	87.46	36999	88.27	35564	88.78	33896	88.84	31955	88.32	29699	87.03

1160 RPM

FAN SIZE	0"SP		1"SP		2"SP		3"SP		4"SP		5"SP		6"SP	
	CFM	BHP	CFM	BHP	CFM	BHP	CFM	BHP	CFM	BHP	CFM	BHP	CFM	BHP
122	1179	0.09												
135	1577	0.14												
150	2163	0.24	1293	0.28										
165	2879	0.38	2020	0.47										
182	3993	0.74	2964	0.83										
200	5256	1.17	4140	1.30	2636	1.24								
222	7237	1.99	5994	2.19	4574	2.21								
245	9281	2.70	8288	3.17	7196	3.45	4930	3.30						
270	12422	4.39	11297	5.06	10251	5.45	8489	5.70						
300	17584	8.31	16291	9.34	15145	9.90	13597	10.21	11083	9.96				
330	23404	13.38	21949	14.84	20710	15.67	19284	16.24	17246	16.46	14173	15.87		
365	30385	20.67	28767	22.66	27401	23.86	25988	24.72	24200	25.31	21712	25.38	18196	24.44

- Notes:
1. Performance certified is for installation type B – Free inlet, Ducted outlet.
 2. Performance ratings do not include the effects of appurtenances (accessories).
 3. Ratings at 70F, 0.075 lbs/ft³ Density, Sea Level Elevation.

Dimensions - Scroll Housing

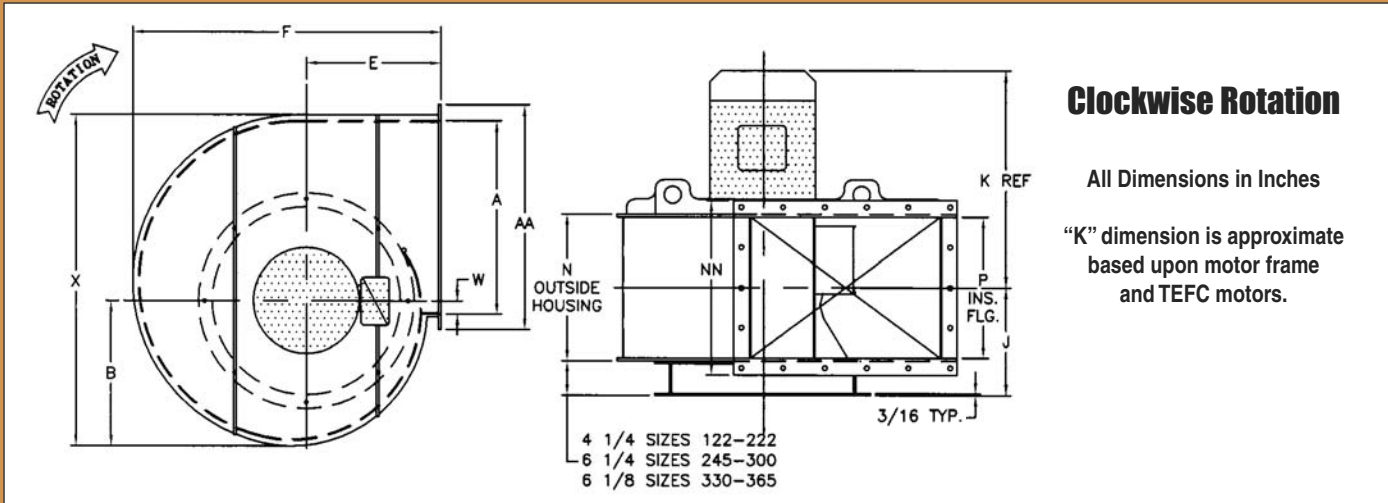

FAN SIZE	Wheel Dia.	A	B	E	F	J	K	N	P	W	X	AA	NN	Motor Frame		Total Weight	FAN SIZE
														Min.	Max.		
122	12-5/8	13-3/4	10-7/8	9-15/16	22-13/16	9-1/8	17-7/16	9-3/4	9-3/8	3/4	24-3/8	17-11/16	13-3/8	143TC	184TC	157	122
135	13-7/8	15-1/4	12-1/16	10-3/16	25-1/16	9-5/8	21-1/4	10-3/4	10-3/8	13/16	27	19-3/16	14-3/8	143TC	215TC	181	135
150	15-3/8	16-13/16	13-1/4	11-3/4	27-7/16	10-1/8	21-3/4	11-3/4	11-3/8	7/8	29-11/16	20-3/4	15-3/8	143TC	215TC	205	150
165	16-7/8	18-7/16	14-1/2	12-11/16	29-7/8	10-11/16	26-11/16	12-7/8	12-1/2	15/16	32-1/2	22-7/16	16-1/2	143TC	256TC	231	165
182	18-5/8	20-3/8	16	13-13/16	32-3/4	11-3/8	33-5/8	14-1/4	13-7/8	15/16	35-15/16	24-1/2	17-7/8	143TC	326TSC	327	182
200	20-3/8	22-3/8	17-1/2	14-15/16	35-11/16	12-1/16	34-5/16	15-5/8	15-1/4	1-1/8	39-1/4	26-3/8	19-1/4	182TC	326TSC	395	200
222	22-5/8	24-7/8	19-3/8	16-3/8	39-3/8	12-7/8	35-1/8	17-1/4	16-7/8	1-1/4	43-1/2	28-7/8	20-15/16	182TC	326TC	458	222
245	25	27-3/8	21-1/4	18-13/16	44-1/16	15-3/4	36	18-15/16	18-9/16	1-3/8	47-3/4	31-3/8	22-5/8	213TC	326TC	581	245
270	27-1/2	30-1/16	23-3/8	20-5/8	48-3/8	16-11/16	36-15/16	20-13/16	20-7/16	1-7/16	52-1/2	34-1/8	24-1/2	213TC	326TC	697	270
300	30-1/2	33-9/16	26	22-5/8	53-1/2	17-13/16	38-1/16	23-1/8	22-3/4	1-11/16	58-3/8	37-5/8	26-3/4	213TC	326TC	832	300
330	33-1/2	36-7/8	24-11/16	24-7/8	58-9/16	18-9/16	38-11/16	24-7/8	24-7/8	1-7/8	64	40-7/8	28-7/8	284TC	365TC	1318	330
365	36-1/2	40-1/4	27-3/16	27-1/4	64-3/16	19-3/4	37-7/8	27-1/4	27-1/4	2	69-3/4	44-1/4	31-1/4	284TC	365TC	1469	365

Flange Dimensions

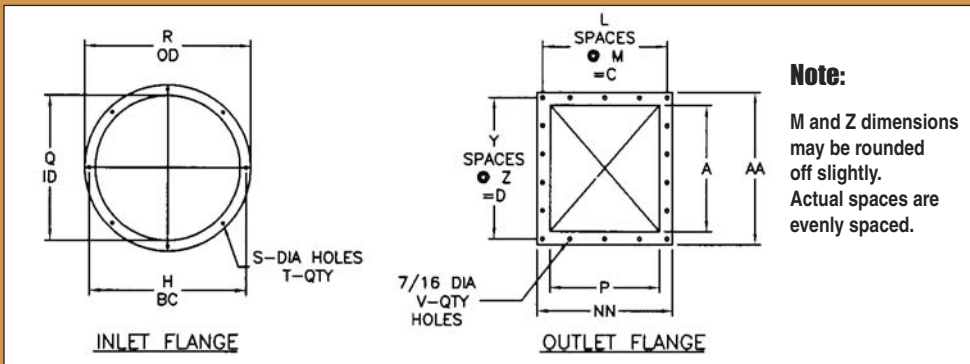

FAN SIZE	Wheel Dia.	C	D	H	L	M	Q	R	S	T	V	Y	Z	FAN SIZE
122	12-5/8	11-3/8	15-11/16	14-3/8	2	5-11/16	12-7/8	16	7/16	8	8	2	7-27/32	122
135	13-7/8	12-3/8	17-3/16	15-15/16	2	6-3/16	14-1/4	17-3/4	7/16	8	8	2	8-19/32	135
150	15-3/8	13-3/8	18-3/4	17-1/2	2	6-11/16	15-3/4	19-1/4	7/16	8	10	3	6-1/4	150
165	16-7/8	14-1/2	20-7/16	19-3/8	2	7-1/4	17-5/8	21-1/8	7/16	8	10	3	6-13/16	165
182	18-5/8	15-7/8	22-1/2	21-1/2	2	7-15/16	19-5/8	23-1/2	7/16	12	10	3	7-1/2	182
200	20-3/8	17-1/4	24-3/8	23-1/2	3	5-3/4	21-5/8	25-1/2	7/16	12	12	3	8-1/8	200
222	22-5/8	18-15/16	26-7/8	26-1/8	3	6-5/16	24-1/4	28-1/8	7/16	12	14	4	6-23/32	222
245	25	20-5/8	29-3/8	28-3/4	3	6-7/8	26-5/8	30-3/4	7/16	16	14	4	7-11/32	245
270	27-1/2	22-1/2	32-1/8	31-5/8	3	7-1/2	29-5/8	33-3/4	7/16	16	14	4	8-1/32	270
300	30-1/2	24-3/4	35-5/8	35-1/4	3	8-1/4	33-1/8	37-1/4	7/16	16	16	5	7-1/8	300
330	33-1/2	26-7/8	38-7/8	38-3/4	5	5-3/8	36-3/8	40-3/8	1/2	16	24	7	5-9/16	330
365	36-1/2	29-7/32	42-1/4	42	5	5-27/32	39-5/8	43-5/8	1/2	16	24	7	6-1/32	365

Discharge and Rotation

Position of Discharge and Rotation (viewed from the drive side)

Clockwise shown, counterclockwise available

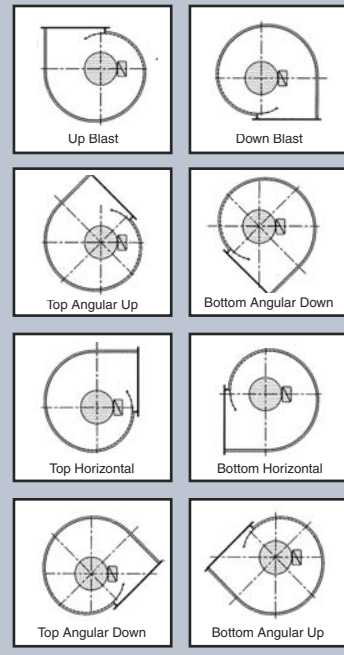

Dimensions - Square Housing

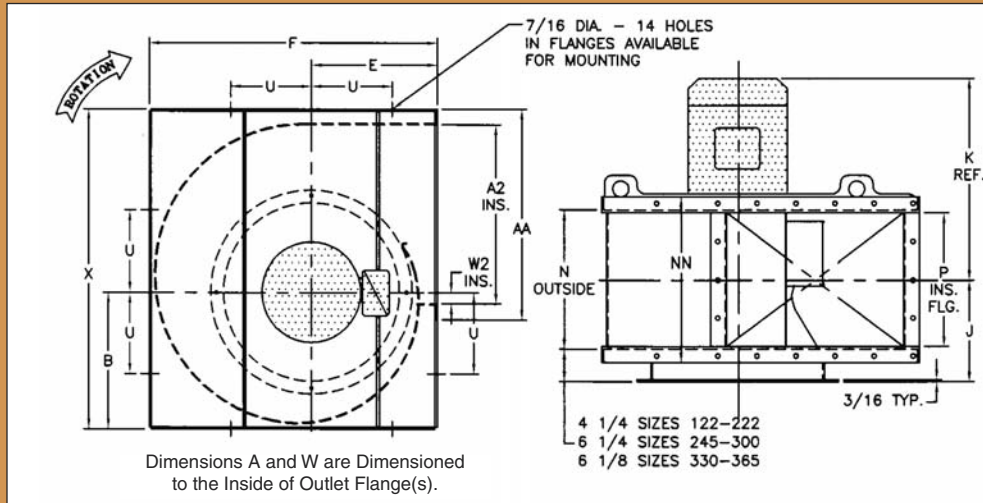

Clockwise Rotation

All Dimensions in Inches

"K" dimension is approximate based upon motor frame and TEFC motors.

FAN SIZE	Wheel Dia.	A	B	E	F	J	K	N	P	U	W	X	AA	NN	Motor Frame		Total Weight	FAN SIZE
															Min.	Max.		
122	12-5/8	13-9/16	10-7/8	9-15/16	22-13/16	9-1/8	17-7/16	9-3/4	9-3/8	7	21/32	25-7/8	17-11/16	13-3/8	143TC	184TC	185	122
135	13-7/8	15-1/16	12-1/16	10-3/16	25-1/16	9-5/8	21-1/4	10-3/4	10-3/8	8	23/32	28-1/2	19-3/16	14-3/8	143TC	215TC	212	135
150	15-3/8	16-5/8	13-1/4	11-3/4	27-7/16	10-1/8	21-3/4	11-3/4	11-3/8	8	25/32	31-3/16	20-3/4	15-3/8	143TC	215TC	240	150
165	16-7/8	18-1/4	14-1/2	12-11/16	29-7/8	10-11/16	26-11/16	12-7/8	12-1/2	9	27/32	34	22-7/16	16-1/2	143TC	256TC	271	165
182	18-5/8	20-1/8	16	13-13/16	32-3/4	11-3/8	33-5/8	14-1/4	13-3/4	11	13/16	37-1/2	24-1/2	17-7/8	143TC	326TSC	391	182
200	20-3/8	22-1/8	17-1/2	14-15/16	35-11/16	12-1/16	34-5/16	15-5/8	15-1/8	11	1	40-1/4	26-3/8	19-1/4	182TC	326TSC	467	200
222	22-5/8	24-5/8	19-3/8	16-3/8	39-3/8	12-7/8	35-1/8	17-1/4	16-3/4	11	1-1/8	45	28-7/8	20-15/16	182TC	326TC	542	222
245	25	27-1/8	21-1/4	18-13/16	44-1/16	15-3/4	36	18-15/16	18-7/16	16	1-1/4	49-1/4	31-3/8	22-5/8	213TC	326TC	681	245
270	27-1/2	29-13/16	23-3/8	20-5/8	48-3/8	16-11/16	36-15/16	20-13/16	20-5/16	16	1-5/16	54	34-1/8	24-1/2	213TC	326TC	813	270
300	30-1/2	33-5/16	26	22-5/8	53-1/2	17-13/16	38-1/16	23-1/8	22-5/8	16	1-9/16	59-7/8	37-5/8	26-3/4	213TC	326TC	968	300
330	33-1/2	36-5/8	28-1/2	24-11/16	58-9/16	18-9/16	38-11/16	24-7/8	24-3/8	16	1-3/4	65-1/2	40-7/8	28-7/8	284TC	365TC	1482	330
365	36-1/2	40	31	27-3/16	64-3/16	19-3/4	37-7/8	27-1/4	27-1/4	16	1-7/8	71-1/4	44-1/4	31-1/4	284TC	365TC	1658	365

Flange Dimensions

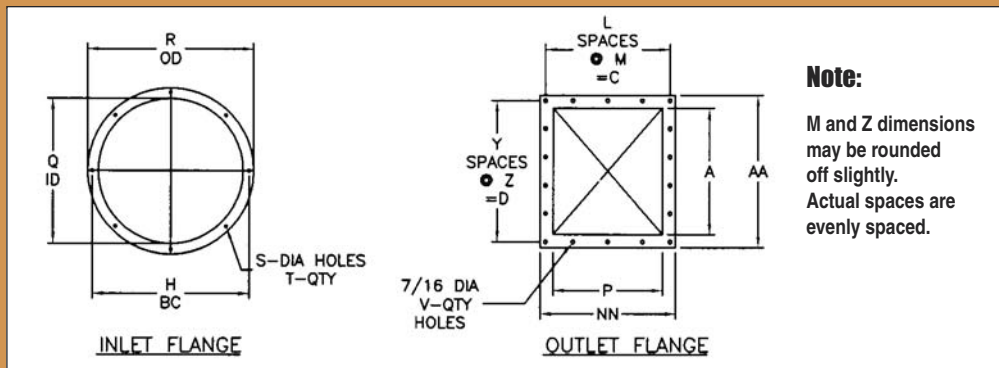

FAN SIZE	Wheel Dia.	C	D	H	L	M	Q	R	S	T	V	Y	Z	FAN SIZE
122	12-5/8	11-3/8	15-11/16	14-3/8	2	5-11/16	12-7/8	16	7/16	8	8	2	7-27/32	122
135	13-7/8	12-3/8	17-3/16	15-15/16	2	6-3/16	14-1/4	17-3/4	7/16	8	8	2	8-19/32	135
150	15-3/8	13-3/8	18-3/4	17-1/2	2	6-11/16	15-3/4	19-1/4	7/16	8	10	3	6-1/4	150
165	16-7/8	14-1/2	20-7/16	19-3/8	2	7-1/4	17-5/8	21-1/8	7/16	8	10	3	6-13/16	165
182	18-5/8	15-7/8	22-1/2	21-1/2	2	7-15/16	19-5/8	23-1/2	7/16	12	10	3	7-1/2	182
200	20-3/8	17-1/4	24-3/8	23-1/2	3	5-3/4	21-5/8	25-1/2	7/16	12	12	3	8-1/8	200
222	22-5/8	18-15/16	26-7/8	26-1/8	3	6-5/16	24-1/4	28-1/8	7/16	12	14	4	6-23/32	222
245	25	20-5/8	29-3/8	28-3/4	3	6-7/8	26-5/8	30-3/4	7/16	16	14	4	7-11/32	245
270	27-1/2	22-1/2	32-1/8	31-5/8	3	7-1/2	29-5/8	33-3/4	7/16	16	14	4	8-1/32	270
300	30-1/2	24-3/4	35-5/8	35-1/4	3	8-1/4	33-1/8	37-1/4	7/16	16	16	5	7-1/8	300
330	33-1/2	26-7/8	38-15/16	38-3/4	5	5-3/8	36-3/8	40-3/8	1/2	16	24	7	5-9/16	330
365	36-1/2	29-7/32	42-7/32	42	5	5-27/32	39-5/8	43-5/8	1/2	16	24	7	6-1/32	365

Discharge and Rotation

Position of Discharge and Rotation (viewed from the drive side)

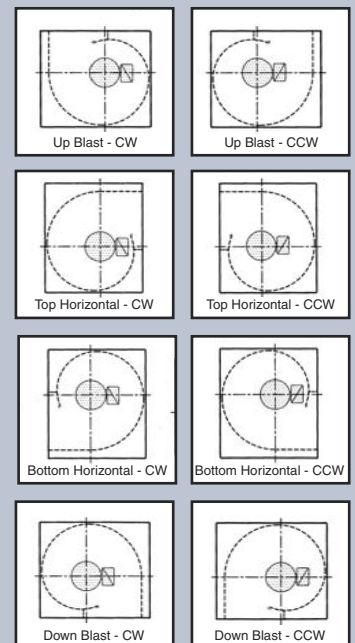

*Setting the
Standard
For Quality*

CHICAGO

*Innovative Engineering
Through Application Analysis*



*Quality Fans
Shaped With
Skill and Pride*



*Global Service Only a
Click Away*

**Sales Offices
Throughout
North America**

*Chicago Blower Fans
are also manufactured
worldwide:*

Argentina, Australia, Brazil,
Chile, China, Colombia,
Denmark, Germany, Greece,
Holland, Hong Kong, India,
Indonesia, Israel, Italy,
Japan, Korea, Malaysia,
New Zealand, Norway,
Philippines, Portugal,
Saudi Arabia, Singapore,
South Africa, Spain, Sweden,
Thailand, Taiwan, Turkey,
Venezuela.



Your Primary Source For Every Fan Requirement

General Duty -

*Airfoil and vane axial
fans for clean exhaust
or supply air*

Industrial Duty -

*Fans to handle
dirty and corrosive
environments*

Heavy Duty -

*Custom engineered
fans for specific
applications*

**CHICAGO BLOWER
CORPORATION**

1675 Glen Ellyn Road, Glendale Heights, Illinois 60139

Phone: 630-858-2600 • Fax: 630-858-7172

www.chicagoblower.com e-mail: fans@chicagoblower.com